

I. O. KOSTIUKOV

DETERIORATION OF XLPE INSULATION IN HIGH VOLTAGE CABLE SYSTEMS AND TESTING OF QUALITY BY APPLYING PULSES OF HIGH VOLTAGE

The wide spreading of energy distribution power cable lines made by means of applying cables with insulation made of cross-linked polyethylene usually is associated with a significant number of advantages in terms of better technical performance that such cables have in comparison with traditional cables with paper-impregnated insulation. Nevertheless, the necessity to ensure a sufficient level of production quality, as well as the requirements for increasing the operating time of power cable lines, make it urgent to develop insulation quality control methods, including control methods which imply applying of testing impulses that simulate overvoltages that occur in power systems due to lightning strikes. The other aspect of this problem is the necessity of the elaboration of physical models for the description of deterioration of XLPE insulation of power cables under the impact of various external factors. For recent years the problem of testing XLPE insulation by high voltage pulses, similarly to the problem of elaboration of physical models for the description of deterioration of XLPE insulation, have been considered by many authors. This paper gives a brief review of some main recent research that have been focused on the problem of endurance and aging of XLPE insulation due to overvoltage caused by various reasons. The main scope was focused on the problem of testing the endurance of XLPE insulation to the voltage pulses that imitate overvoltage due to lightning strikes. Some of the theories of aging of dielectric materials under the impact of impulse and alternating electrical fields and the influence of these factors on lifetime of dielectric materials have also been discussed.

Keywords: pulse overvoltage, deterioration of XLPE insulation, space charge, water tree channels.

I. O. КОСТЮКОВ

СТАРІННЯ ПОЛІЕТИЛЕНОВОЇ ІЗОЛЯЦІЇ У ВИСОКОВОЛЬТНИХ КАБЕЛЬНИХ СИСТЕМАХ ТА КОНТРОЛЬ ЯКОСТІ ІЗ ВИКОРИСТАННЯМ ІМПУЛЬСІВ ВИСОКОЇ НАПРУГИ

Проведено стислий огляд основних наукових досліджень, в яких розглядається проблема стійкості ізоляції із зшитого поліетилену до дії перенапруг, що викликані різними причинами, а також проблема старіння ізоляції вказаного типу під дією перенапруг різного характеру. Основна увага приділена проведенню випробувань стійкості поліетиленової ізоляції до сформованих імпульсів, що імітують перенапруги які виникають внаслідок ударів блискавки. Проведено огляд деяких теорій старіння діелектричних матеріалів під дією змінних та імпульсних електричних полів та вплив цих факторів на ресурс ізоляції.

Ключові слова: імпульсні перенапруги, старіння ізоляції із зшитого поліетилену, об'ємний заряд, водні трірінги.

I. A. KOSTIUKOV

СТАРЕНИЕ ПОЛИЭТИЛЕНОВОЙ ИЗОЛЯЦИИ В ВЫСОКОВОЛЬТНЫХ КАБЕЛЬНЫХ СИСТЕМАХ И КОНТРОЛЬ КАЧЕСТВА С ИСПОЛЬЗОВАНИЕМ ИМПУЛЬСОВ ВЫСОКОГО НАПРЯЖЕНИЯ

Проведен краткий анализ основных научных исследований, в которых рассматривается проблема стойкости изоляции из сшитого полиэтилена к воздействию перенапряжений, возникающих под действием различных причин, а также проблема старения изоляции указанного типа под действием перенапряжений различного характера. Основное внимание уделяется проведению испытаний стойкости полиэтиленовой изоляции к сформированным импульсам перенапряжения, которые имитируют перенапряжения возникающие вследствие ударов молнии. Проведен анализ некоторых теорий старения диэлектрических материалов под действием переменных и импульсных полей и влияния этих факторов на ресурс изоляции.

Ключевые слова: импульсные перенапряжения, старение изоляции из сшитого полиэтилена, объемный заряд, водные тринги.

Introduction. The reliability of modern high voltage power cable systems with cross-linked polyethylene insulation and the endurance of such insulation to numerous disruptive external factors are of considerable interest from the point of view of reducing the expenses on renovation and the increasing the reliability of energy

distribution systems. The solution of this problem partially may be achieved by applying comprehensive system of control tests, that can allow to control the quality of manufacturing process. Recent trends in practice of diagnostics the technical state of power cable lines enhance the responsibility of manufacturer for the

© I. O. Kostiukov 2019

technical performance of their production.

According to the statistics obtained in practice of KEMA high-voltage laboratory for 6 years (1993-1998) and described in [1], the level of failures during testing procedures can reach 26% (including the amount of failures in cable accessories). Such result, obviously, can be considered as quite a substantial level, which can be a consequence of an insufficient level of manufacturing or miscounts on a stage of elaboration of constructions. Problems of this kind cause quite a significant interest to the elaboration of models for the deterioration of dielectric materials under the influence of certain factors and to the development of different techniques for their testing.

The purpose of this paper is to provide a succinct review of recent models that describe the deterioration of XLPE insulation and requirements to the process of testing of XLPE insulation of power cables by applying pulses of high voltage.

Basic mechanisms of deterioration of XLPE insulation. Classical theories of breakdown in solid dielectric materials distinguish several main types of breakdown [2]. Electrical type of breakdown usually takes place due to the disruption of structure of solid material which is caused by the avalanche of electrons that can occur during the collision ionization in dielectric. This type of breakdown can be characterized by the short duration of development and insignificant impact of temperature rise due to power losses in dielectric material. Mentioned aspects make it rather difficult to attain this type of breakdown under practical conditions of operation of power cable lines. Thermal type of breakdown usually takes place due to the heating of dielectric material caused by power losses. This type of breakdown has longer duration of development in time in comparison with previously mentioned electrical breakdown.

The majority of models for electrical or thermal aging of insulation imply exponential expressions for lifetime. Nevertheless, for the case of aging of dielectric material under the influence of electrical field the expression for lifetime for many practical cases quite often can be written in the following form [3]:

$$\tau = A \cdot E^{-m}, \quad (1)$$

where τ – lifetime of dielectric material;

E – electric field strength;

A and m – empirical coefficients.

Thermal aging of dielectric materials can be described by means of applying exponential expression (Arrhenius equation):

$$\tau = A \cdot e^{\frac{W}{kT}}, \quad (2)$$

where k – Boltzmann constant;

T – temperature;

W – activation energy of aging process.

Many of recently developed models for electrical aging of dielectric materials have been built on the bases of exponential expressions for lifetime of dielectric material, similarly to the case of thermal aging. Nevertheless, the applying of such models often implies dealing only with certain parameters that characterize conditions of carried out experiment, for example the

value of electric field strength of the beginning of partial discharges, or the value of frequency of applied electric field.

The most significant drawback of models of mentioned type is that they hardly can accurately predict the influence of such important factors as humidity, variation of temperature, and morphology of dielectric materials on their lifetime. In fact, in this case many models of electrical aging partially can be taken as models for approximation of experimental data which include certain parameters, quite often with the unknown origin. In other cases such models can include certain parameters that determine the conditions of held experiment.

Aging of dielectric materials under the influence of electric field is often attributed to the action of partial discharges and to the presence of some volume charge in dielectric materials due to the injection of electrons from the surface of electrodes. One of the first of suggested models of aging that involves parameters of dielectric material was described in [4]:

$$\tau = \frac{h}{2kT} e^{\frac{\Delta G - e\lambda E}{kT}}, \quad (3)$$

where h – Plank constant;

λ – scattering length;

e – the value of electrical charge of electrons;

ΔG – Gibbs free energy, which can be determined by using (4) [3]:

$$-\frac{\Delta G}{kT} = \ln E(c + \frac{d}{T}), \quad (4)$$

where c and d – adjustable constants.

Further development of aging model (3) has been made in [5]. This model is based on the considerations of the disruption of van der Waals forces between the molecules of polymeric material, which are considerably weaker in comparison with intramolecular bonds, as an important stage of the breakdown process. This disruption of intermolecular bonds occurs due to the injection of charges in submicrocavities formed in dielectric material with their further acceleration under the forces of applied field and gaining their kinetic energy up to values which can be sufficient for the disruption of intramolecular bonds. The elaborated in [5] model of aging was intended for the description of the prebreakdown processes in dielectric i. e. for the intermediate region between the area of comparably low electric fields, that correspond to sufficient endurance of dielectric material, and the region of high electric field and short lifetime of dielectric. According to this theory the time, which is necessary in order to attain the final state of aging, can be expressed as [5]:

$$t = \frac{h}{2kT} e^{\frac{\Delta G}{kT}} \csc h\left(\frac{e\lambda E}{kT}\right) \quad (5)$$

The process of destruction of intramolecular bonds can be accompanied with the process of rebound of separated chains. The difference between the rate of breaking chains and the rate of rebound chains in fact represents the rate of bonds disruption according to [5]:

$$t = \frac{h}{2kT} e^{-\frac{\Delta G}{kT}} \sinh\left(\frac{e\lambda E}{kT}\right). \quad (6)$$

However, the analysis of the endurance of cables with XLPE insulation to the applied voltage, especially after some aging during their service under practical conditions of operation, usually is carried out on the basis of consideration of electrochemical type of breakdown. In the context of applying to the issue of endurance of polyethylene insulation to applied voltage, including the endurance to overvoltage pulses with high frequency components, the consideration of such type of breakdown often includes models that intent to describe the development of electric and water tree channels in XLPE insulation, which eventually can lead to the breakdown.

Recent studies have established a drastic effect of service aging of XLPE insulation with tree-retardant additive on impulse electric strength, which can lead to approximately 50% decreasing of impulse electric strength after two years of service [6]. Such result has been explained by the development of water tree channels in insulation. Statistical model of water tree growth in XLPE insulation with tree-redundant additive, which has been described in [7], takes into consideration thermal effects that can lead to rather prompt disruption of cross-linked polyethylene. Proposed in [7] mechanism of deterioration is based on a comparison of time constants of polarization for a water filled channel with the duration of a rise time of applied pulse of voltage. The value of time constant of a water filled channel can be determined according to (7) [7].

$$\tau = \frac{10^{-19}}{r^2 \sigma}, \quad (7)$$

where r – radius of water channel;

σ – electrical conductivity of water.

According to the mentioned model for the mechanism of deterioration, the increasing of time constant (7) above the duration of a rise time of applied pulse leads to the increasing of heat diffusion due to the currents in the channel. Smaller values of time constant lead to the decreasing of heat due to conduction in water tree channels.

Sometimes the modeling of distortions of electrical field caused by water tree channels is carried out by applying numerical methods and modern software for calculation of three-dimensional electromagnetic fields. Such modeling, which has been carried out in [8], displayed the effects of destruction of polyethylene structure by compression forces acting at the ends of the water-filled channels.

The endurance of XLPE insulation to the development of water tree channels can be determined according to testing method described in [9]. The implementation of testing method implies formation of water needles, in a form of a recess which is filled with an electrolyte, in a sample of tested material. During the testing procedure this water needle acts as a high-voltage electrode. The criterion for failure of tested sample usually is accepted as the breakdown of tested sample, the formation of electrical tree channels or the increasing of the length of water tree channel to any value above the $300 \cdot 10^{-6}$ m.

Testing of quality of high voltage cable systems by applying pulses of high voltage. Practical conditions of operation of power cable with XLPE insulation demand to take into consideration the influence of overvoltage on the reliability of power cable lines, as their insulation can be subjected to overvoltage of different origin. Typical examples of such overvoltage can be induced overvoltages which occur due to lightning strikes that can penetrate in cable line in combined power transmission lines that consist of overhead lines and underground power cable lines [10]. Another reason for overvoltage can be caused by arc discharges which can occur in three-phase power transmission lines which operate with insulated neutral in case of phase to earth fault [11].

In practice it is possible to distinguish several different techniques for carrying out such high voltage tests, which intend to determine the endurance of XLPE insulation to high voltage pulses. According to described in [12] requirements, testing procedure can contain tests with the level of voltage that corresponds to the general requirements to dielectric strength of XLPE insulation and with the level of voltage that exceeds these requirements.

General requirements to the procedures of testing of power cables 6-36 kV by means of applying pulses of high voltage described in [12].

Table 1 gives general requirements to the values of endurable testing voltage for such cables according to [12].

Table 1 – General technical requirements to the value of endurable amplitude of pulse voltage for cables with plastic insulation according to [12]

Voltage of power cable, kV	Amplitude of pulse voltage, kV
6	60
10	75
15	95
20	125
30	170
35	190

Table 2 – General technical requirements to the value of endurable amplitude of pulse voltage for cables according to [13]

Voltage of power cable, kV	Amplitude of pulse voltage, kV
11	75
33	170
66	325
132	550

Generated pulses of high voltage should fit pretty strict requirements to their time dependences. Usually generated pulse of voltage that imitates overvoltage due to the lightning strike should have the duration of rise time equal to 1.2 μ s. The duration of fall time of generated pulses is supposed to be equal to 50 μ s. For power cables within the rate of voltage 6-36 kV the admissible deviation of amplitude of generated pulse should be within the borders of $\pm 3\%$. Admissible deviation of the

duration for the fall time of generated pulse should be within the borders of $\pm 20\%$. For the case of long samples and, therefore, significant electrical capacitance of tested sample, the increasing of rise time to $5 \mu\text{s}$ is permitted. In case of distortions of the form of generated high voltage pulse near its amplitude caused by high frequency oscillations their amplitude should not exceed the value of the amplitude of main pulse more than on 5%. According to the general requirements described in [12] the insulation of tested cable should be able to endure 10 pulses of voltage with positive polarity and 10 pulses of voltage with the opposite polarity.

Besides the electrical tests which can be carried out by applying pulses of high voltage with their amplitude that corresponds to the necessary values (for example the values of amplitude given in table 1), it is possible to carry out tests by applying pulses with amplitude that exceeds necessary values. In this case testing process consists of several series of applying high voltage pulses to the tested sample with further gradual increasing of voltage with some necessary step. For example, according to [14] the first stage of high voltage tests contains applying of 3 pulses of positive and negative polarity with amplitude that corresponds to the basic requirements to the endurance of pulse voltage. Further stages imply increasing of voltage in steps of 25% above the basic level with further applying of 3 negative pulses on each step. According to the other requirements, which have also been described in [14], tests on the basic level of applied voltage, similarly to [12], contain 10 pulses of high voltage of positive and negative polarity. Further stages of the test are carried out with increased on 5% amplitude above the level of the previous step. Each stage should contain 10 voltage pulses of each polarity. Such tests can detect impurities and protrusions in insulation due to their deterioration under the impact of such pulses [15]. Another important aspect of such type of tests is that they can be used for the purposes of studying the accumulation of space charge in insulation layers. Aging of high density polyethylene insulation by applying series of 3000 pulses that imitate overvoltage due to lightning strikes, which was carried out in [16], has shown rather significant injection of space charge after the process of aging.

In practice in the majority of cases generation of voltage pulses is carried out by applying scheme of Marx generator, despite such disadvantages as necessity of applying significant amount of spark gaps and considerable geometrical size. For this case forming of necessary voltage pulse is carried out by applying front resistance and tail resistance. Mathematical modeling of transients in testing systems based on applying of equivalent circuit of high voltage generator and detailed scheme of generator, that takes into consideration electrical parameters of each stage, in case of operation of Marx generator on a capacitive load has shown quite a significant difference between the values of tail resistance which have been obtained by means of applying the equivalent circuit model of high voltage generator and detailed model, which contains parameters of stages. This modeling was carried out under the assumption of

capacitive load of generator that corresponds to the case of tested power cable. In some cases the presence of semi conductive screens that cover the core and insulation of power cable and some stray inductance can demand to take into consideration the influence of mentioned parameters on transients and not to consider tested power cable as a purely capacitive object. More detailed equivalent scheme of tested power cable includes stray inductance of power cable and parameters that describe properties of semi conductive screens [17].

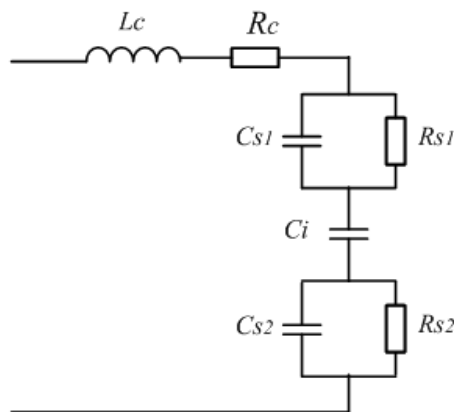

Fig.1. Detailed equivalent scheme of short sample of power cable

On the equivalent scheme presented on Fig.1 C_{S1} and C_{S2} designate the values of electrical capacitance of semi conductive layers that cover the surface of the core of power cable and its insulation. R_{S1} and R_{S2} designate the values of electrical resistance of semi conductive layers. C_i is the value of electrical capacitance of the main insulation. L_s and R_s designate the values of series inductance and resistance.

Conclusions. Pulse overvoltage in high voltage cable systems usually is considered in the context of aging of XLPE insulation due to the injection of space charge and disruption of van der Waals forces between the molecules of polymeric material. High voltage tests with applying generated pulses of high voltage are among other typical techniques to ensure sufficient level of manufacturing. This urges manufacturers of cable production to carry out such kinds of tests. However, pretty strict requirements to generated pulses of high voltage in some cases demand to take into consideration the presence of stray parameters of power cable.

References

1. *Berlijn S. M.* Type testing of cables and accessoires / *S. M. Berlijn, R. J. B. Gruntjes, G. P. T. Roelofs* // Proceedings of the 5th International Conference on Power Cables. Paris-Versailles 1999.
2. *Tareev B. M.* Electrical engineering materials / *B. M. Tareev, N. P. Bogorodickij, V. V. Pasyukov.* – Moscow.: Mir, 1979. – 360 p.
3. *Parpal Jean-Luc.* Electrical aging of extruded dielectric cables. Review of existing theories and data / *Luc Parpal, Jean-Pierre Crine, Chinh Dang* // IEEE Transactions on Dielectric and Electrical Insulation. – 1996. – Vol. 3. – № 2. – p. 237 – 247.

4. *Crine J. P.* A molecular approach to the physico-chemical factors in the electrical breakdown of polymers / *J. P. Crine, A. K. Vijh* // Applied Physical Communications. – 1985. – Vol. 3. – p. 139 – 163.
5. *Parpal Jean-Luc.* Electrical aging of extruded dielectric cables. A physical model / *Jean-Luc Parpal, Jean-Pierre Crine, Chinh Dang* // IEEE Transactions on Dielectric and Electrical Insulation. – 1997. – Vol. 4. – № 2. – p. 197 – 209.
6. *Katz C.* Field monitoring of parameters and testing of EP and TR-XLPE distribution cables / *C. Katz, B. Fryszczyn, M. Regan, W. Banker, B. Bernstein* // IEEE Transactions on Power Delivery. – 1999. – Vol. 14. – p. 679 – 684.
7. *Boggs S. A.* Mechanisms for degradation of TR-XLPE impulse strength during service aging / *S. A. Boggs* // IEEE Transactions on power delivery. – 2002. – Vol. 17. – № 2. – p. 308 – 312.
8. *Kucheriava I. M.* Coupled electrical and mechanical processes in polyethylene insulation with water tree having brunches of complex structure / *I. M. Kucheriava* // Technical Electrodynamics. – 2016. – № 5. – p. 5 – 10.
9. *Пешков И. Б.* Специальные методы исследований и испытаний электрической изоляции силовых кабелей среднего и высокого напряжения / *И. Б. Пешков, В. Л. Овсиенко, М. Ю. Шувалов* // Кабели и провода. – 2015. – № 1. – с. 9 – 14.
10. *Borghetti A.* Insulation coordination of MV cables against lightning-induced overvoltages generated by LEMP-coupled overhead lines / *A. Borghetti, M. Marzinotto, C. Mazzetti, C. A. Nucci, M. Paolone* // Proceedings of the 28th International Conference on Lightning Protection. Kanazava 2006. p. 783 – 788.
11. *Екимукое С. С.* Особенности эксплуатации кабелей с изоляцией из сшитого полиэтилена (защита от перенапряжений, диагностика и испытания) / *С. С. Екимукое, И. Ю. Цивилев* // Кабели и провода. – 2011. – № 2. – с. 22 – 27.
12. ГОСТ Р 55025-2012. Кабели силовые с пластмассовой изоляцией на номинальное напряжение 6 – 35 кВ включительно. Общие технические условия. Москва, Стандартинформ, 2014. 35 с.
13. *Kumar A.* Simulation of impulse voltage generator in different impulse voltages for testing of underground power cables in MATLAB/SIMULINK / *A. Kumar, R. Singh* // Global journal of engineering science and researches. – 2016. – Vol. 3. – № 10. – p. 31 – 35.
14. *Barmji S. S.* Electroluminescence technique to evaluate the effect of impulse tests on high voltage cables / *S. S. Barmji, M. Kaufhold, A. T. Bulinsli* // IEEE Transactions on Dielectric and Electrical Insulation. – 1998. – Vol. 5. – № 2. – p. 204 – 210.
15. *Woschitz R.* Quality control of XLPE cables by means of impulse voltage test / *R. Woschitz, W. Panosch, G. Knollseisen, C. Sumereder* // Proceedings of the Conference on Electrical Insulating Materials. Vol. 2. Kitakyushu, 2005.
16. *Dao N. L.* Lightning impulse aging of HV cable insulation / *N. L. Dao, P. L. Lewin, S. G. Swinger* // Proceedings of the 16th International Symposium on High Voltage Engineering. Johannesburg, 2009. Paper C-6.
17. *Bhuyan K.* Simulation of lightning impulse voltage stress in underground cables / *K. Bhuyan, M. Taro, S. Chatterjee* // Proceedings of the International Conference on Condition Assessment Techniques in Electrical Systems. Bangalore 2009. p. 34 – 39.

References (transliterated)

1. *Berlijn S. M.* Type testing of cables and accessoires / *S. M. Berlijn, R. J. B. Gruntjes, G. P. T. Roelofs* // Proceedings of the 5th International Conference on Power Cables. Paris-Versailles 1999.
2. *Tareev B. M.* Electrical engineering materials / *B. M. Tareev, N. P. Bogorodickij, V. V. Pasyukov.* – Moscow.: Mir, 1979. – 360 p.
3. *Parpal Jean-Luc.* Electrical aging of extruded dielectric cables. Review of existing theories and data / *Luc Parpal, Jean-Pierre Crine, Chinh Dang* // IEEE Transactions on Dielectric and Electrical Insulation. – 1996. – Vol. 3. – № 2. – p. 237 – 247.
4. *Crine J. P.* A molecular approach to the physico-chemical factors in the electrical breakdown of polymers / *J. P. Crine, A. K. Vijh* // Applied Physical Communications. – 1985. – Vol. 3. – p. 139 – 163.
5. *Parpal Jean-Luc.* Electrical aging of extruded dielectric cables. A physical model / *Jean-Luc Parpal, Jean-Pierre Crine, Chinh Dang* // IEEE Transactions on Dielectric and Electrical Insulation. – 1997. – Vol. 4. – № 2. – p. 197 – 209.
6. *Katz C.* Field monitoring of parameters and testing of EP and TR-XLPE distribution cables / *C. Katz, B. Fryszczyn, M. Regan, W. Banker, B. Bernstein* // IEEE Transactions on Power Delivery. – 1999. – Vol. 14. – p. 679 – 684.
7. *Boggs S. A.* Mechanisms for degradation of TR-XLPE impulse strength during service aging / *S. A. Boggs* // IEEE Transactions on power delivery. – 2002. – Vol. 17. – № 2. – p. 308 – 312.
8. *Kucheriava I. M.* Coupled electrical and mechanical processes in polyethylene insulation with water tree having brunches of complex structure / *I. M. Kucheriava* // Technical Electrodynamics. – 2016. – № 5. – p. 5 – 10.
9. *Peshkov I. B., Ovsienko V. L., Shuvalov M. Ju.* / Special'nye metody issledovanij i ispytanij jelektricheskoy izoljacji silovyh kabelej srednego i vysokogo naprjazhenija [Special methods of research and testing of electrical insulation of power cables of medium and high voltage]. Kabeli i provoda. 2015, no. 1, pp. 9 – 14.
10. *Borghetti A.* Insulation coordination of MV cables against lightning-induced overvoltages generated by LEMP-coupled overhead lines / *A. Borghetti, M. Marzinotto, C. Mazzetti, C. A. Nucci, M. Paolone* // Proceedings of the 28th International Conference on Lightning Protection. Kanazava 2006. p. 783 – 788.
11. *Ekimukov S. S., Civilev I. Ju.* Osobennosti jekspluatatsii kabelej s izoljaciej iz sshitogo

- polijetilena (zashhita ot perenaprjazhenij, diagnostika i ispytaniya) [Features of operation of cables with insulation made of cross-linked polyethylene (overvoltage protection, diagnostics and testing)]. Kabeli i provoda. 2011, no. 2, pp. 22 – 27.
12. GOST P 55025-2012 Kabeli silovye s plastmassovoj izoljaciej na nominal'noe naprjazhenie 6 – 35 kV vkljuchitel'no. Obshhie tehicheskie uslovija. [GOST P 55025-2012 Power cables with plastic insulation for rated voltage 6 - 35 kV. General technical circls]. Moscow, Standartinform, 2014. 35 p.
 13. Kumar A. Simulation of impulse voltage generator in different impulse voltages for testing of underground power cables in MATLAB/SIMULINK / A. Kumar, R. Singh // Global journal of engineering science and researches. – 2016. – Vol. 3. – № 10. – p. 31 – 35.
 14. Barmji S. S. Electroluminescence technique to evaluate the effect of impulse tests on high voltage cables / S. S. Barmji, M. Kaufhold, A. T. Bulinsli // IEEE Transactions on Dielectric and Electrical Insulation. – 1998. – Vol. 5. – № 2. – p. 204 – 210.
 15. Woschitz R. Quality control of XLPE cables by means of impulse voltage test / R. Woschitz, W. Panosch, G. Knollseisen, C. Sumereder // Proceedings of the Conference on Electrical Insulating Materials. Vol. 2. Kitakyushu, 2005.
 16. Dao N. L. Lightning impulse aging of HV cable insulation / N. L. Dao, P. L. Lewin, S. G. Swingler // Proceedings of the 16th International Symposium on High Voltage Engineering. Johannesburg, 2009. Paper C-6.
 17. Bhuyan K. Simulation of lightning impulse voltage stress in underground cables / K. Bhuyan, M. Taro, S. Chatterjee // Proceedings of the International Conference on Condition Assessment Techniques in Electrical Systems. Bangalore 2009. p. 34 – 39.

Received 01.04.2019

Відомості про авторів / Сведения об авторах / About the Authors

Костюков Іван Олександрович (Костюков Иван Александрович, Kostiukov Ivan Aleksandrovich) – кандидат технічних наук, старший викладач кафедри електроізоляційної та кабельної техніки НТУ «ХПІ», м. Харків. e-mail: iakostiukow@gmail.com 70-76-544